

NP PREMADE SERIES NP185

Compact & versatile, the easy solution for pre-made pouches.

FORMATS

Starting from a pre made pouch of heat-sealable material the Machine picks de pouches from a customized magazine or a multi format motorized belt, to place it in the machine's line, starting with a positive opening to fill with product, and while is transferred to the next station stretches the pouches to avoid wrinkles and have a correct sealing at the top of the pouch ensuring their tightness.



NP PREMADE SERIES NP185



Versatile, Flexible and Productive, our Pre-Made is ideal for medium and low product lots/series of Stand Up Pouches up to 1,5 liters and Flat Sachets up to 800 cc. Designed for all the applications and products.

	Format (mm)		Volume	Output	Consumption	Dimensions	Weight
	Min	Max	(cc)	(spm)	Kw	(mm)	Kg
NP-185	80 x 110 x 35	190 x 300 x 90	1500	50	4,2	3,228 x 2,542 x 2,084	1,5

Going Beyond the others, Flexpack's Premade machine can be adapted with a Top Spout Applicator and can easily open premade pouches with Zipper due to the special opening system.

Technical Specifications	
SACHET DIMENSIONS:	Minimum: 90 x 110 x 35 mm (Large x Height x Gusset). Maximum: 190 x 300 x 100 mm (Large x Height x Gusset).
VOLUME:	1.500 cc
MECHANICAL OUTPUT:	Up to 50 CYCLES
ELECTRIC CONSUMPTION	4.2 kW
ELECTRICAL DATA:	Standard 220/400 V, 3 Ph, 50/60 Hz. + Hz. + Terre. Other voltages available on request.
MACHINE DIMENSIONS:	Net Weight: 1.500 kg. 3,228 x 2,542 x 2,084 mm (L x W x H).

NP PREMADE SERIES

NP185

Measurements in mm

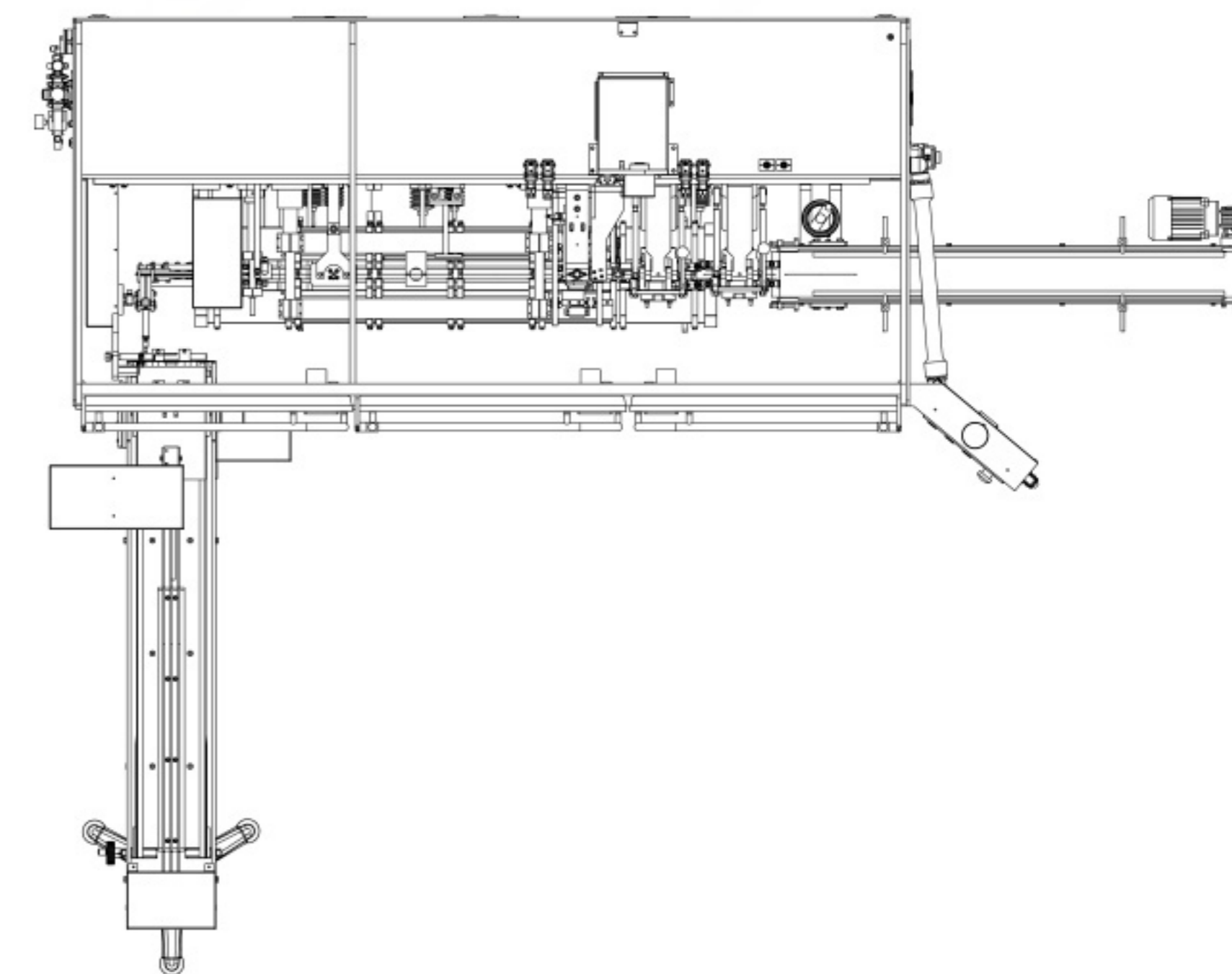
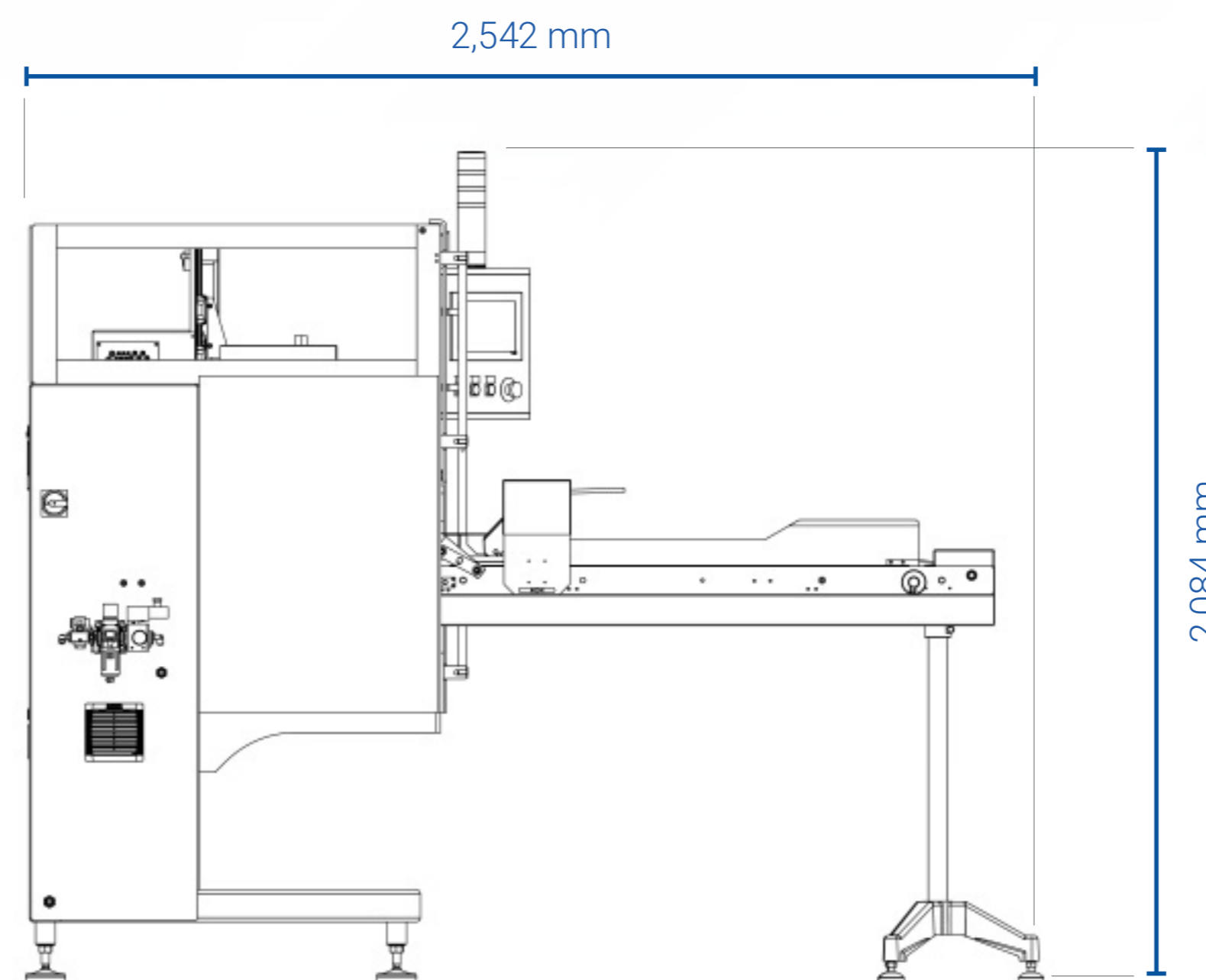
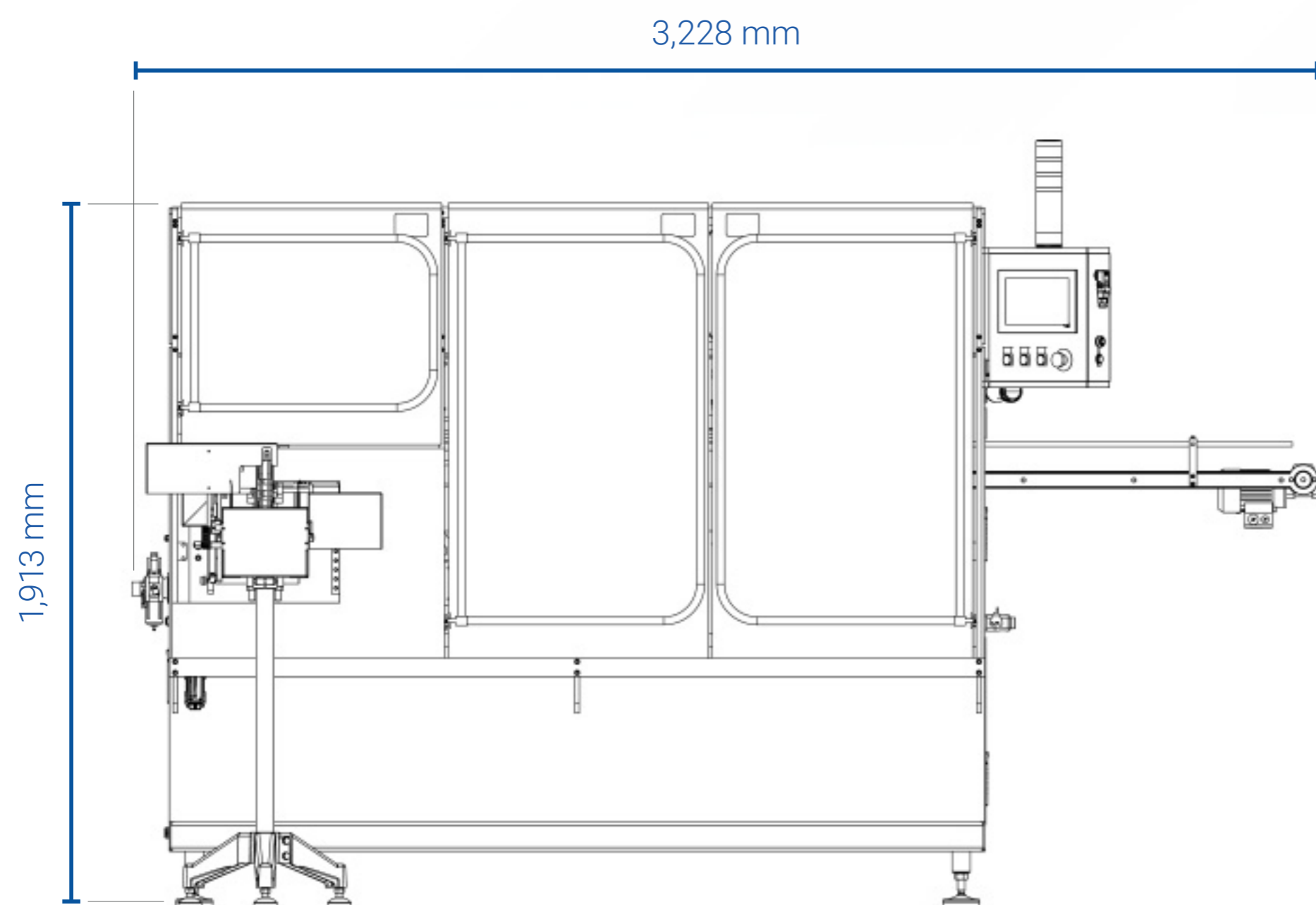

FEATURES

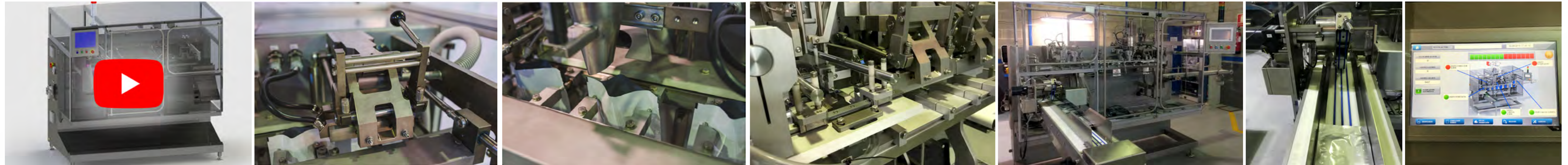

- Ergonomic Monoblock on Balcony Frame.
- Machine manufactured on Stainless Steel 304
- Ecofriendly:
 - Reduced cost of maintenance.
 - Reduced energy expenditures.
- Adjustable Motorized Belt for multi format and easy change over.
- Special opening system for formats with zipper closed.
- B&R Automation with Ethernet Connection.
- High Resolution Touch Screen 10".

- Remote IP Assistance.
- Clean and Accessible Filling Stations.
- Easy operation
 - Watertight Hoppers
 - Pneumatic Funnel Vibrator
 - Static Pouch Stretching Prior top Seal.
 - Special Belt for heavy weight formats.
- Wash-down design available on request.
- Maximum connectivity with all kinds of peripherals.

Top Spout Applicator

Device that guarantees accurate spout's positioning in the upper side of the pouch. The spout is placed after filling station and before the upper sealing. The group is composed by:

- Level Detector.
- Vibratory bowl feeder.
- Step by step system and spout positioning system.
- Spout welder.



Powder and Granulated



Liquid and Pasty



Towelettes



Solids



Stand up retort and microwave



FLEXPACK
Flexible Packaging Machines

Camí del Cementiri s/n nave 19, Pol. Ind. Can Ribot, 08319 Dosrius · Barcelona (Spain)
Tel. +34 931 598 000 · info@flexpack.es

www.flexpack.es
