

# Flat Sachet Series



Avinguda del Mogent, 266-268  
Pol. Ind. Llinars Park  
08450 Llinars del Valles, Barcelona, Spain  
Phone +34 931 598 000  
info@flexpack.es

[www.flexpack.es](http://www.flexpack.es)



## INNOVATION AND TECHNOLOGY



Flexible packaging makes thousands of products more convenient, enjoyable, and safer for consumers.

## ENVIRONMENTAL SOLUTIONS



Less Waste in the First Place:

- Uses less energy and water consumption
- Efficiency on Transportation
- Smaller Footprint Processes

## MATERIAL AND RESOURCE EFFICIENCY



Food and consumer products  
Packaging **90%**  
Saves much more resources than it consumes.  
Footprint average less than 10%

## TRANSPORTATION BENEFITS



**1** Truck full of flexible packaging  
**More of 25** Trucks full of glass jars  
Up to 85% of Savings Space:  
1 Truck = 100,000 pcs Plastic Bottle  
1 Truck = 700,000 pcs Flexible Pouch

## PACKAGING, SUSTAINABLE SOLUTIONS



Material innovations, such as biodegradable materials.  
Reused materials = Pouches to make new packs.  
Use better materials to make it easy to recycle.

## CONSUMER CONVENIENCE



Flexible packaging is lightweight, making it easy to carry, easy to open, easy to use, easy to store, and easy re-seal.

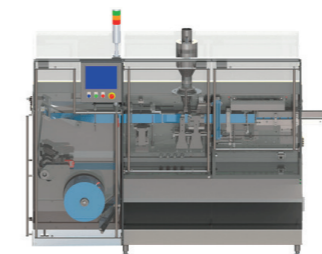

**NF-110 Series**

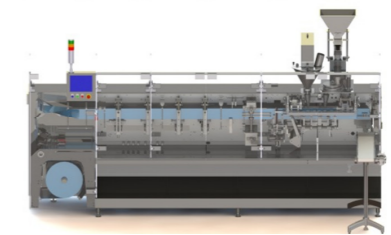

**NF-Flat Sachet Series**

# NF-110 Series

HANDY, COMPACT AND PRODUCTIVE.

High productivity on a very small space floor. **Ideal for small sachets 3 or 4 sides seal, unitary, twin and strings.** Major application for **powders, solid and pasty products.**

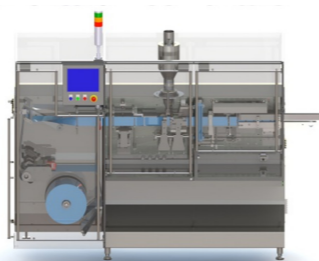

# NF-Flat Series

VERSATILITY, FLEXIBILITY AND PRODUCTIVITY, THE ALL IN ONE MACHINE.

Higher Performance Packaging Machines, **easy and quick changeover, flexible and efficient.** Ideal for medium sachets sizes, unitary, twin, spout, zipper and shapes. Major application for **all kind of products and sectors.**

**Easy Operation, Low cost of Maintenance, Reduced Energy's Expenditure Minimum Billing in Spare Parts, Ecofriendly.**

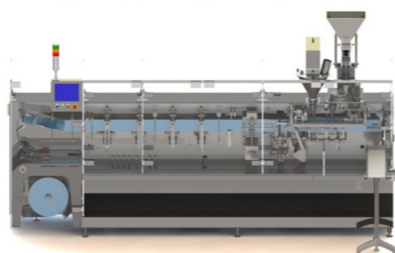

## RANGES

	Simplex (mm.)		Duplex (mm.)		Volume (cc.)	Mechanical Output (ppm)
	Width	Height	Width	Height		
<b>NF-110</b>	40x40	110x130	40x40	70x130	60/30	110/220
<b>NF-110 TWIN</b>	40x40	110x130	40x40	70x130	60/30	200/400
<b>NF-140</b>	50x70	140x200	50x70	70x200	300/80	100/200
<b>NF-150</b>	50x60	150x200	50x60	75x200	325/100	100/200
<b>NF-180</b>	50x70	190x250	50x70	90x250	450/125	90/180
<b>NF-220</b>	100x120	220x250	70x120	110x250	800/200	60/120
<b>NF-280 QX</b>	-	-	50*4x60	70*4x230	100	240



3 AND 4 SIDE SEAL



TWIN



STRINGS



SHAPES



SHAPED WELDING



GUSSETED BOTTOM



TOP SPOUT



WIPES

## MAIN FEATURES

- Ergonomic Monoblock on Balcony Frame.
- Motorized Unwinder with End of Reel Detector.
- Splicing Table for Easy Change of Reel.
- Expandable Reel Support for Easy Mechanical Adjustment with no tooling (Manual)
- High Resistance Protections on Unwinder
- Machine Screws in AISI 304.
- Servo Driven Stroke System by Rollers
- Easy Operation System
  - Micrometers in Sealing jaws for easy changeover
  - Watertight Hoppers.
  - Clean and Accessible Filling Stations.
  - Areas in Contact with Product in AISI 304.
  - Pneumatic Funnel Vibrator.
  - Opener Pharma Type with Internal Drive.
  - Vacuum Pump / Vacuum Controlled by Venturi.
  - Easy Change Scissors.
  - Static Pouch Stretching Prior top Seal.
- B&R Automation with Ethernet Connection.
  - High Resolution Touch Screen 8,4"
  - Ultimate Generation Servomotors
  - Recipe Backup by USB
  - Remote IP Assistance.
- Ecofriendly
  - Low cost of Maintenance
  - Reduced Energy's Expenditure
- Connectivity with Peripherals:
  - Metal Detector,
  - Weight Control,
  - Printers (Inkjet, Laser)
  - Filling Systems
  - Cap, Zipper, Valve Applicators.

## OPERATION DIAGRAM

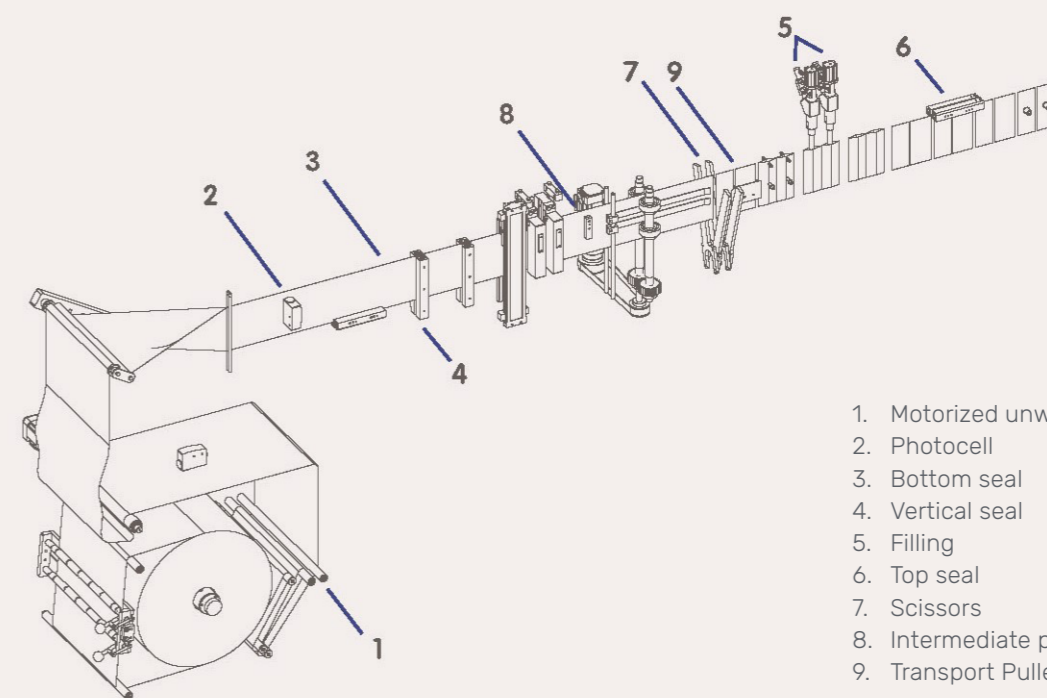

1. Motorized unwinder
2. Photocell
3. Bottom seal
4. Vertical seal
5. Filling
6. Top seal
7. Scissors
8. Intermediate perforation
9. Transport Pulley