

TEDELTA
CAPPING SOLUTIONS

CAPPING SOLUTIONS

TEDELTA MACHINES

Specializing in Complete Capping Systems for the
Bottling and Packaging Industry



The Heart of TEDELTA: The capping machines.

Our commitment in capping technology, allows us to offer tailor made capping Turrets and capping machines to filler equipment manufacturers and complete capping systems to the end user. More than 40 years of experience, gives us total control of our design and manufacturing of our equipment; cappers, turrets and capping heads makes us the main Spanish capper manufacturer.

OUR CAPPING MACHINES

- Our capping machines are designed for high production markets and for the demanding and reliable application of caps.
- Pre-threaded screw caps (flat caps and sport caps), flip-top caps, aluminium caps, snap-on caps, etc...



Capping Machines

Our know-how

Giving shape to our customers' projects.

We are specialists in creating tailor-made solutions that meet the highest production requirements. We design and manufacture machines for all levels of production: from small series of 1.500 bph, through medium productions, up to speeds of 60.000 bph, always adapting to the customer's needs, thanks to the number and type of capping heads installed.

Our commitment to quality and innovation guarantees that each machine is perfectly adapted to the expectations and requirements of each client.

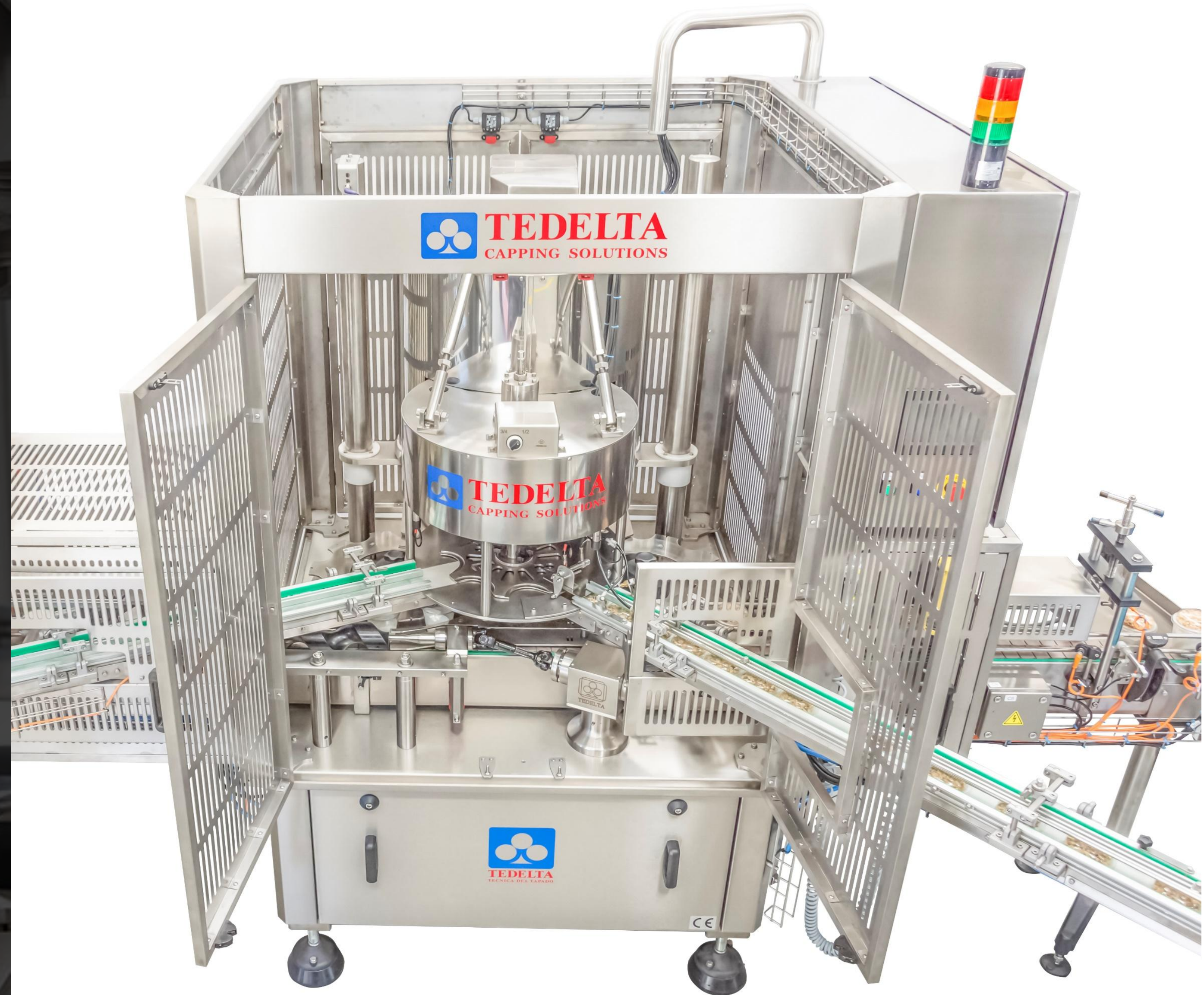

CAPPING MACHINES

Two Capping Systems:



SYSTEM

Pick & Place

The system uses an articulated arm to pick up the cap from the chute and position it precisely on the head, facilitating an accurate and efficient sealing of the container.

SYSTEM

Pick-off

This system uses an advanced cap-stealing mechanism when the bottle gets through the chute, allowing it to collect and placement of the cap with minimal physical contact, thus ensuring the integrity and sterility of the final product



Our capping systems

Pick-off

Pick & Place

Cap delivery:
Pick-off system

Roll- on Capping
Head TEDELTA
CR-504-ST

Cap-
dispenser

Cap delivery:
Pick and place

Chute

Magnetic Capping
head with grippers
CM-706-TR/PZ

Caps
dispenser



TAPONES Y APLICACIÓN

Tecnological Precision

The Pick and Place system offers an adaptable and efficient solution for a wide range of closure types. Their ability to handle different materials, sizes and shapes, together with their advanced positioning and quality control technology, makes them an ideal choice for modern production lines looking for flexibility and precision in the capping process.

Plastic or metal caps:

- Sport Caps
- Push-Pull Caps
- Twist-off Caps
- Snap-on Caps
- Dosing Caps(Flip top, pump, trigger..)
- Push and turn safety caps.
- Valve Caps.

1. PICK & PLACE SYSTEM



SECTORS OF APPLICATION

FOOD INDUSTRY



BEVERAGES

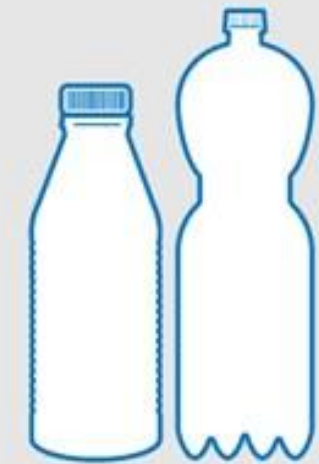

PHARMA



QUÍMICOS

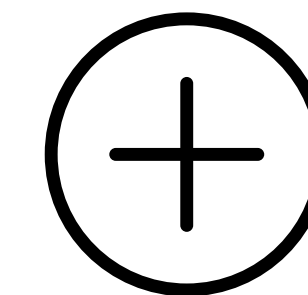
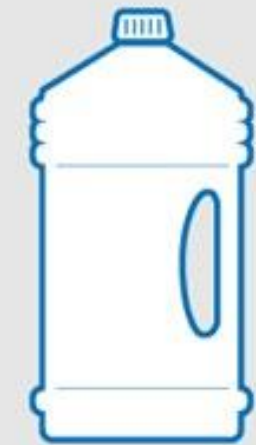

COSMÉTICOS



PICK & PLACE SYSTEM

FULL AUTOMATIC SCREW
CAPPING MACHINE
Type: "Lineal"
TEDELTA-CAL-101-ST

- Great flexibility that allows the capper to be equipped with a variety of different heads such as: magnetic CM-706-TR, Push-on CP-101, SERVO capping head.
- It reaches productions up to 3000 bottles-hour.
- Automatic cap positioning and feeding system designed for a specific cap.

MACHINE WITH 1 HEAD

Low Productions



PICK & PLACE SYSTEM

FULL AUTOMATIC ROTARY
CAPPING MACHINE
Type: "Transfer" (Pick and Place)

TEDELTA-CAR-106/8-TR

- Machine with capping head model TEDELTA CM, -706-TR.
- Starting at 3000 bph and reaching a high output of 60000 bph with maximum efficiency depending on the number of heads installed.
- CE Regulatory compliance.

CAPPING MACHINES

Medium and high productions



ALUMINIUM SCREW CAPS

Technological Accuracy

- Short skirt R.O.P.P.
- Long skirt R.O.P.P
- Extra long skirt R.O.P.P, etc...



CAPPING MACHINE PIECES

PICK-OFF SYSTEM

Cap dispenser

Cap feeder elevator

Capping turret

ROPP Capping head

Pick off

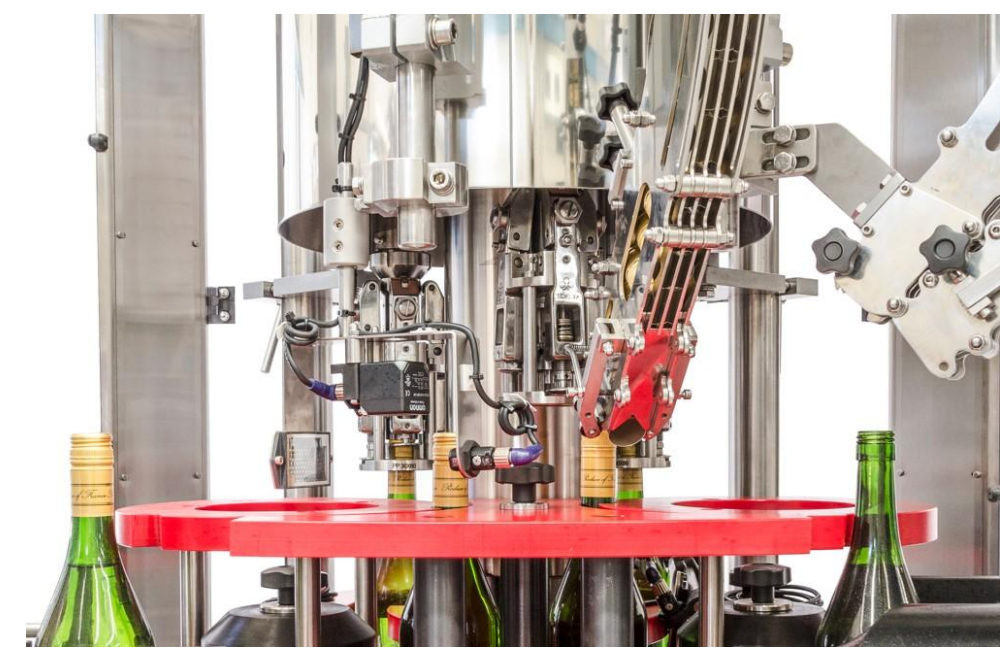

PICK-OFF SYSTEM

Semiautomatic CSA-101



- Quick and easy capping head changes.
- Easy manual bottle height adjustment, permitting cap closures of small or large bottles.
- Independent variable speed motor allowing capping head revolution adjustment for different caps and bottles.
- Low maintenance, minimum grease system and high durability

CAPPING MACHINES

Low Productions

Automatic: Inline CAL-101-ST



- Equipped with our most sophisticated and versatile Head, TEDELTA CR-504-ST.
- Automatic cap positioning and feeding system adapted to cap specifications.
- Small run production lines reaching capping capacity of 3000 bph.

PICK-OFF SYSTEM

Model: CAR-100-ST



- Machine equipped with capping head, TEDELTA CR-504-ST.
- From 3000 bph up to 60000 bph with maximum efficiency.

CAPPING MACHINES

ROTARY PICK OFF SYSTEM

Model: Duplex Monoblock



- Two or three capping turrets integrated in one machine.
- Each capping turret allows independent use of different cap dispensing systems such as; Pick and Place and Pick-off, depending on the cap to be applied.

PICK-OFF SYSTEM

CAPSULATING CYCLE

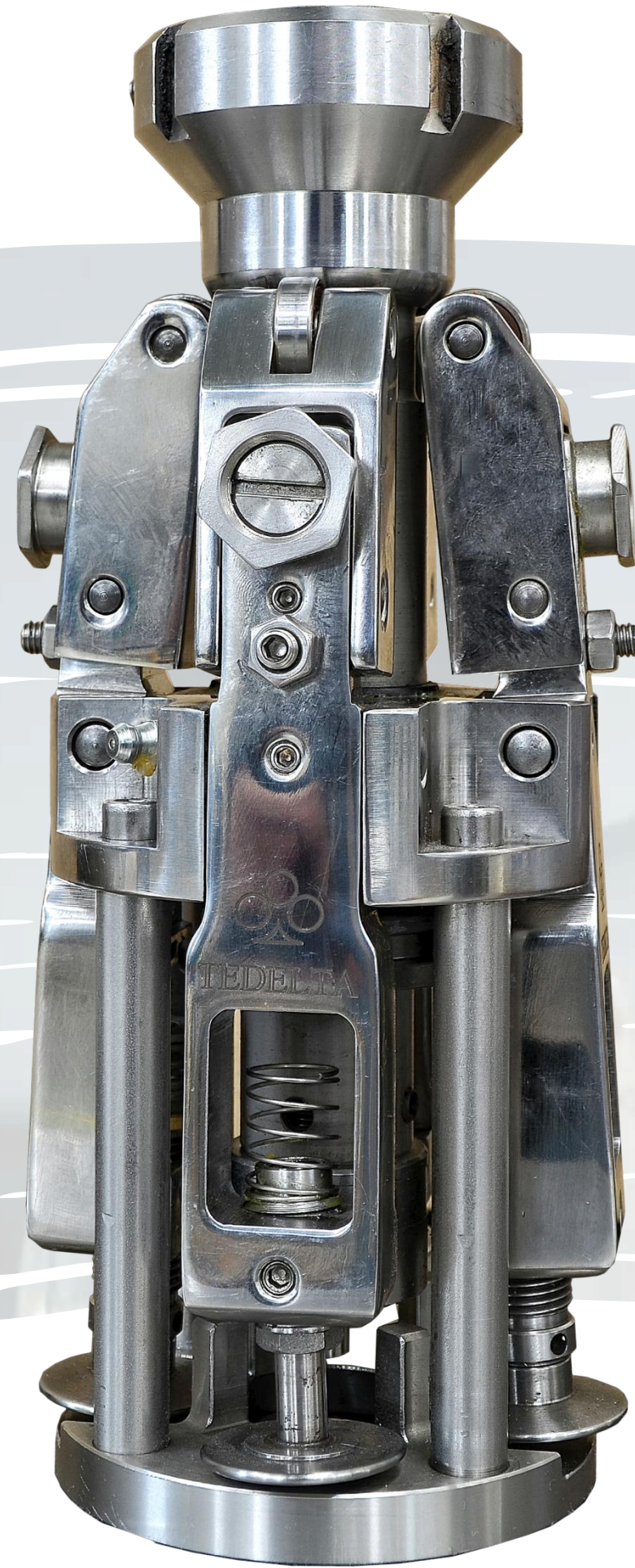

TEDELTA CR-504-ST

- The capping head is design to creat a perfect seal betwen the SPP capsule and the bottle.
- The capping process is the following, the capping head lowers rotating on its own axis of symmetry until it makes contact with SPP capsule exerting through the spring and pressure block, the appropriate vertical pressure to ensure the compression of the seal.
- The ROPP capping head is equipped with articular armas which radially moves bringing the rollers (the thread and seal ones) into contact with the capsule with the necessary lateral pressure. The thread and seal rollers shape the capsule by threading and sealing it, respectly.
- Onces the capsule is closed, the head ascends, realising the cap from the rollers.
- CAP DISTRIBUTION
 - Hooper-Rotatory distributor (mmechanical or centrifugar) .
 - Distributor by vibration system.
- CAP PICK UP- Pick-off.

PICK-OFF SYSTEM

TEDELTA HEAD CR-504-ST

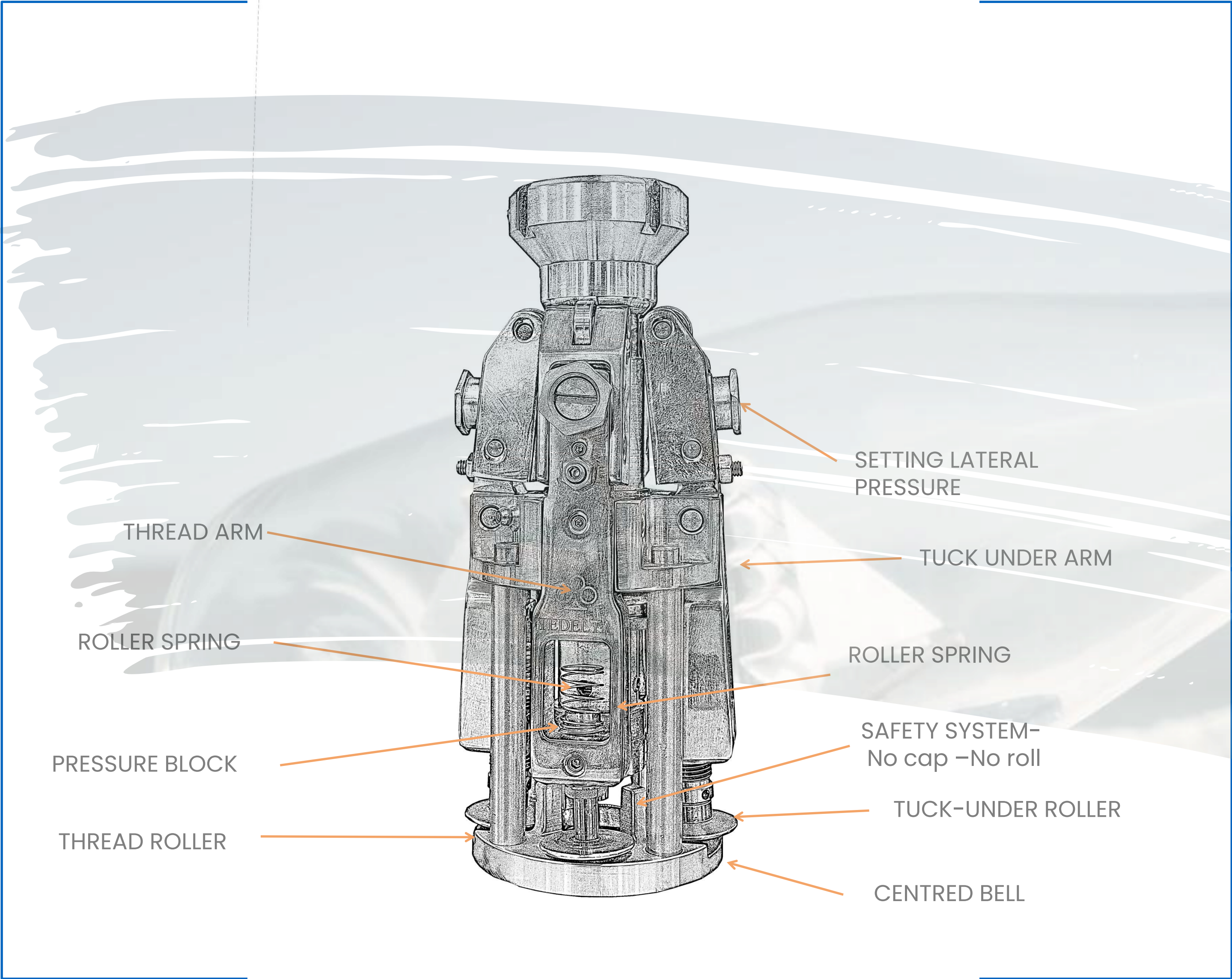

- Manufactured in bronze or stainless steel.
- Designed to perform a perfect and accurate seal of bottles with PP cap.

PICK-OFF SYSTEM

TEDELTA CAPPING HEAD CR-804-ST

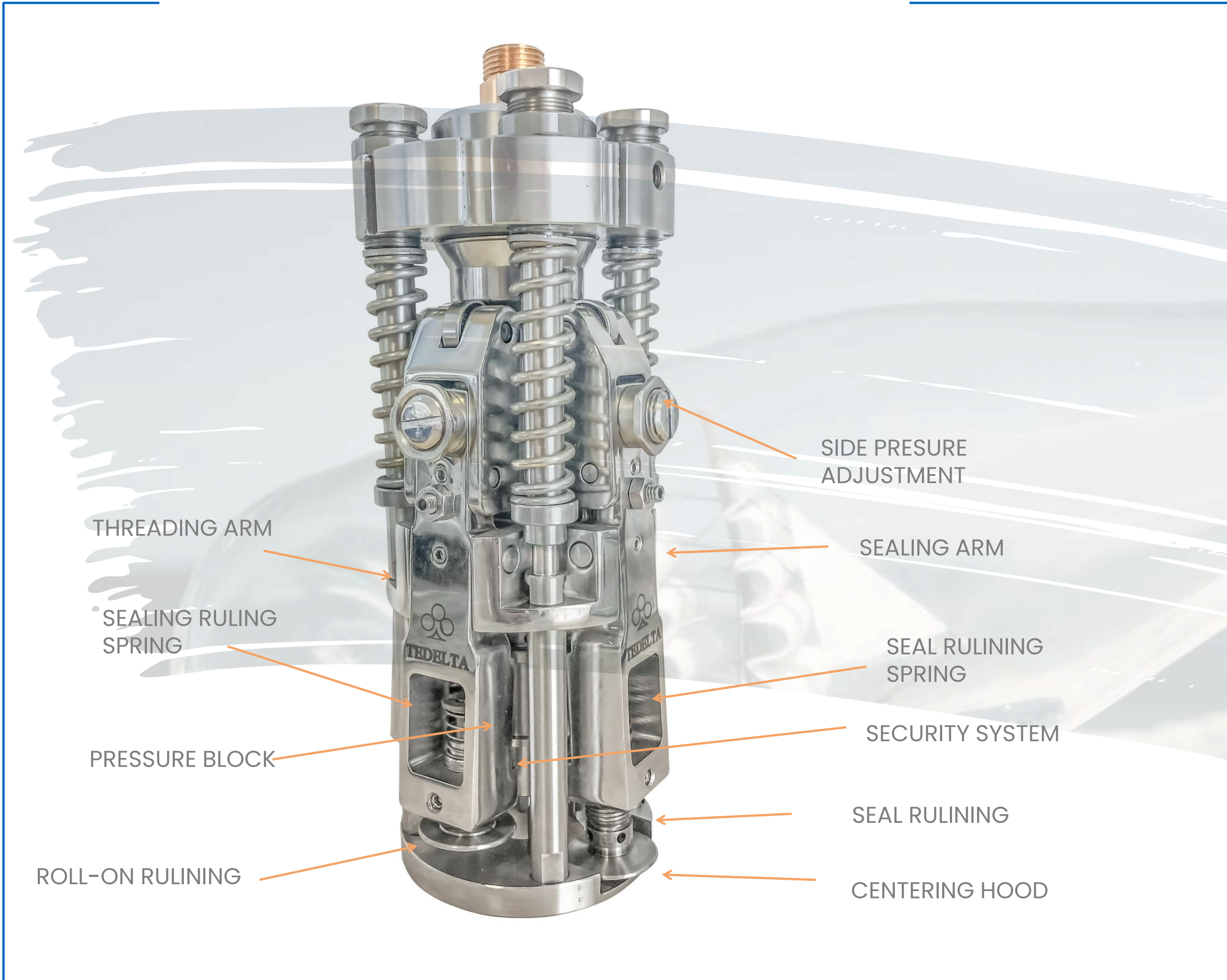

- Build in bronze or stainless steel.
- Design to perform a secure and perfect sealing process for containers with SPECIAL 35 mm caps.

TURRETS

The heart of our machines.

Tedelta's Turrets are manufactured for high volume production markets and for reliable and demanding work process. Our equipment will process from 3000 bph to 60000 bph depending on the number of heads installed.

- Plastic pre threaded caps .
- Flat caps and sport caps
- Flip-top caps.
- Push-on caps.
- Special caps
- Etc..



TURRET

Technological Accuracy

Three options adapted to the needs of our costumers:

- 1.- Integration into Monoblocks or Triblocks.
- 2.- Specific solutions for end users of bottling lines, replacing existing capping turret.
- 3.- Capping unit of our stand alone machines, to be integrated into bottling lines.

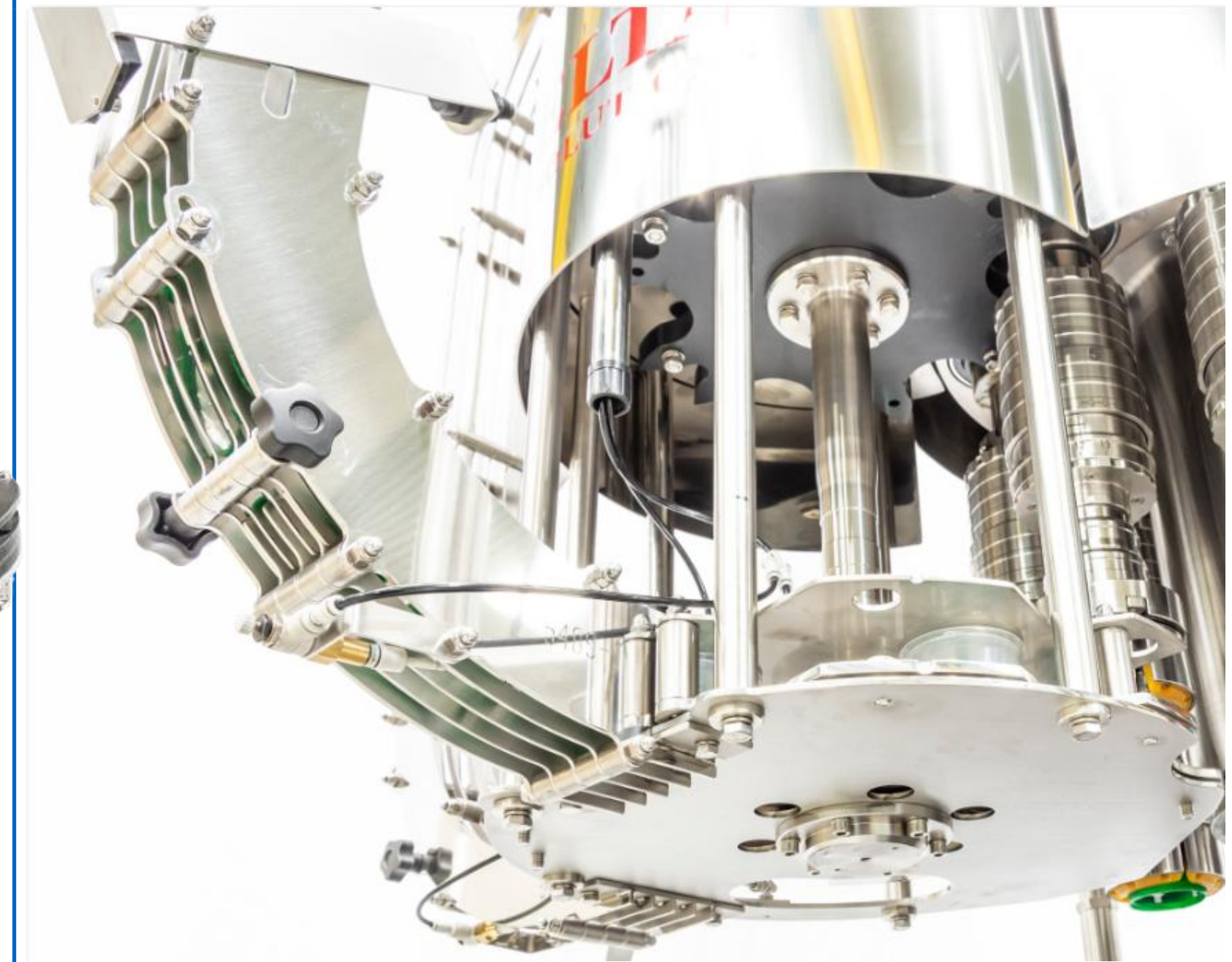

CAP DISTRIBUTOR

Centrifugar Hooper



Mechanical Hooper



CAP FEEDER ELEVATOR



- Stainless steel execution.
- Adaptable designs according to the project.
- With hopper-cap storage, capacity approx. 0,8m³
- Enclosed in transparent methacrylate material, formed by hinged lids allowing both Access and visualization of the caps.
- High and inclination adjustable, and with a cap outlet tray facilitating the fall of the caps into the hopper.
- Complies with European Conformity regulation C€



TEDELTA INTERNATIONAL

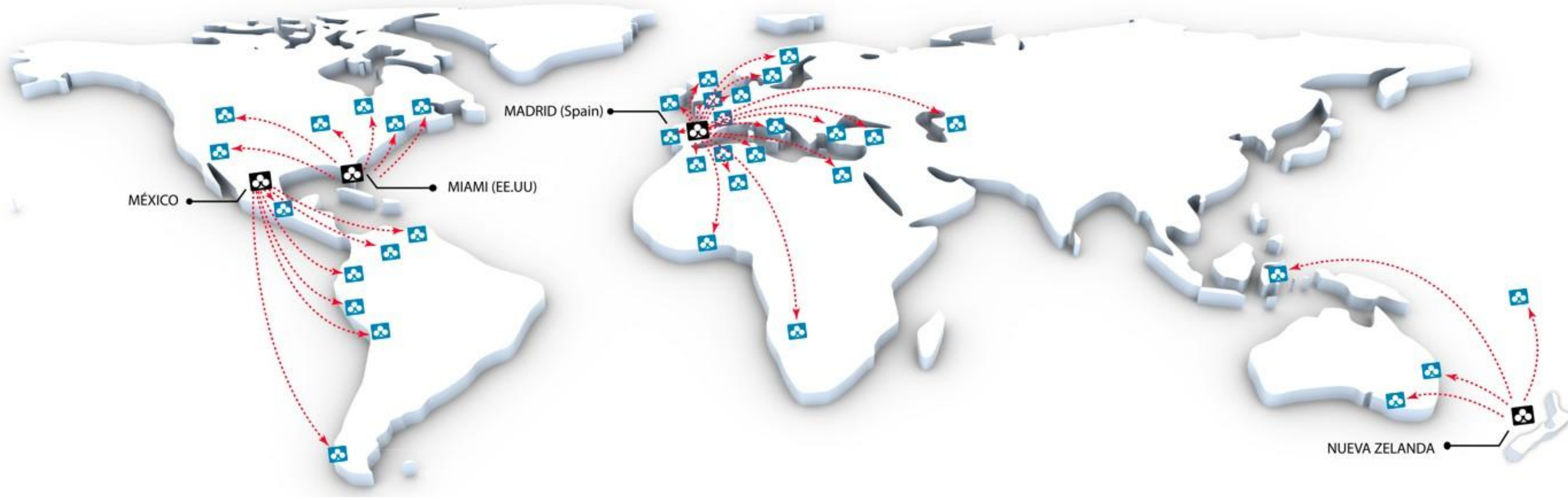

Our commitment to our clients pushes us to higher levels of Service. At Tedelta , we guarantee the fastest and highest quality service assistance, minimizing production downtimes and keeping possible technical problems and maintenance costs at the lowest levels possible.

Watch our machines in action

Click Here:



On our YouTube channel, you can see our machines in action, learn about their key technical features, and watch operational videos.

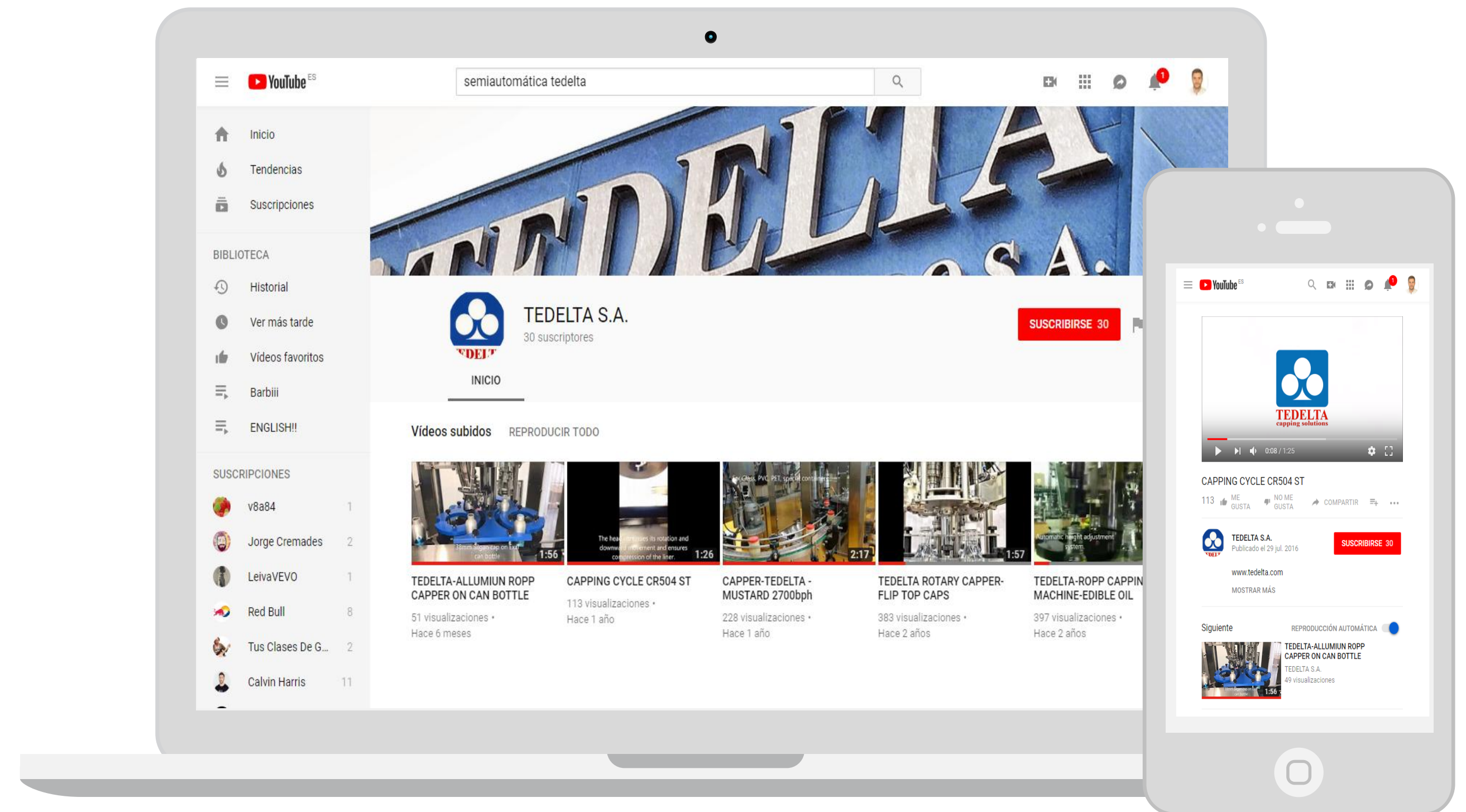

Stay in touch with Us

MAIN OFFICE AND
MANUFACTORY

PHONE:+34 91 642 09 43

E-MAIL:

EXPORT@TEDELTA.COM
ALCOTANES, 29, 28320

PINTO, MADRID

SPAIN



COMMERCIAL OFFICE-USA

PHONE: +1 561-531-1561

EMAIL:

SALES.NORTHAMERICA@TEDELTA.COM

2335 suite R 63 rd AVE. E

Bradenton, Fl

34203

UNITED STATES

